

● **Features:**

1. Open angle: 140° double action
2. Door hold open section: 90° and 140°-120° (Optional)
3. Two speeds adjustable
 Valve 1: 90°-0°
 Valve 2: 30°-0°

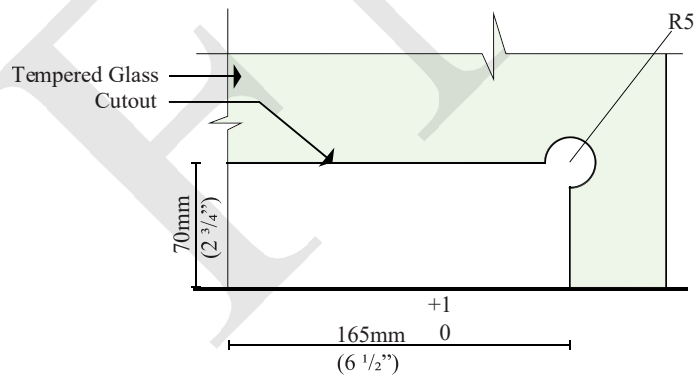

● Keep the gaps as per drawing, make sure the top and bottom pivot center are well aligned.

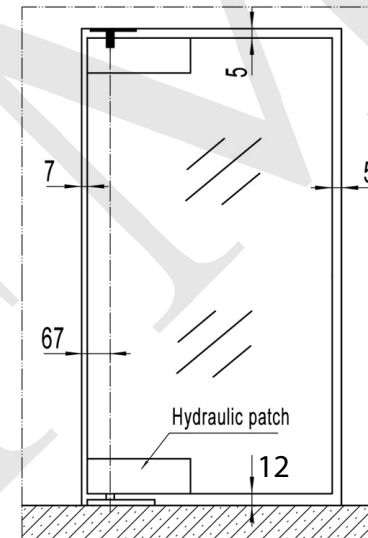

Model	Max. door width (mm)	Max. door weight (kg)	Glass Thickness	Application of rubber gasket
			Thickness	Thickness (1.5mm)
HYP-100	≤1000	100	10mm	4
			12mm	4

NOTES:

- PROPRIETARY AND CONFIDENTIAL - THE INFORMATION CONTAINED IN THIS DRAWING IS THE SOLE PROPERTY OF FMF GLASS HARDWARE. ANY REPRODUCTION IN PART OR AS A WHOLE WITHOUT THE WRITTEN PERMISSION OF FMF GLASS HARDWARE IS PROHIBITED.

PRODUCT NAME:
Standard-Duty Hydraulic Hinge- 100kg

PRODUCT MODEL NUMBER:
HYP-100

DWG NO.
HYP-100_1
 DATE:
01.22

UNIT:
MM
 DRAWN BY:
FMF

DWG SIZE/SCALE
A4/NTS

FMF GLASS HARDWARE

REV. **1**
 SHEET 1 OF 1