

-Features:

Hold open at 90°.

- Keep the gaps as per drawing, make sure the top and bottom pivot center are well aligned.

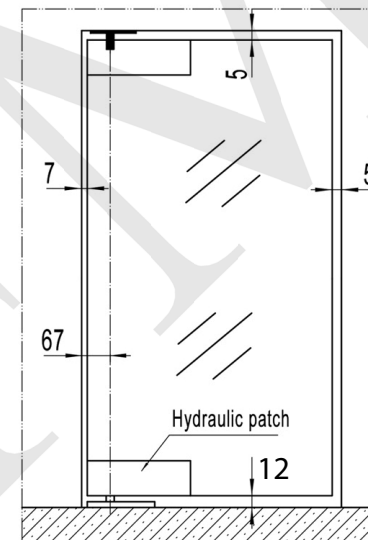
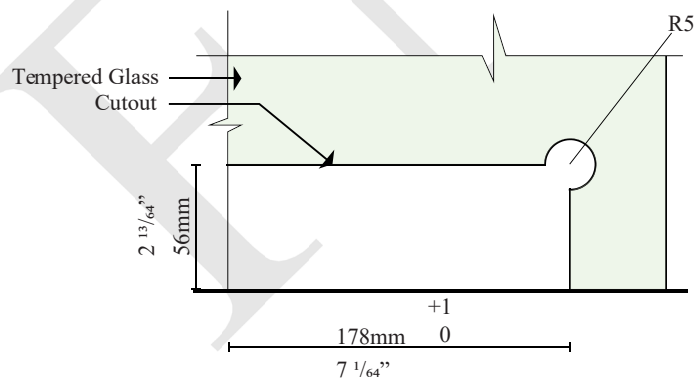

Model	Max. door width (mm)	Max. door weight (kg)	Glass Thickness	Application of rubber gasket
				Thickness (1.5mm)
HYP-80	≤1000	80	10mm	4
			12mm	4

NOTES:

- PROPRIETARY AND CONFIDENTIAL
 - THE INFORMATION CONTAINED IN THIS DRAWING IS THE SOLE PROPERTY OF FMF GLASS HARDWARE. ANY REPRODUCTION IN PART OR AS A WHOLE WITHOUT THE WRITTEN PERMISSION OF FMF GLASS HARDWARE IS PROHIBITED.

PRODUCT NAME:

Light-Duty Hydraulic Hinge- 80kg

PRODUCT MODEL NUMBER:

HYP-80

DWG NO.

HYP-80_1

UNIT:

MM

DWG SIZE/SCALE

A4/NTS

FMF GLASS HARDWARE

REV.

1

DATE:

01.22

DRAWN BY:

FMF

SHEET 1 OF 1