

12 11 10 9 8 7 6 5 4 3 2 1

H  
G  
F  
E  
D  
C  
B  
A

H  
G  
F  
E  
D  
C  
B  
A

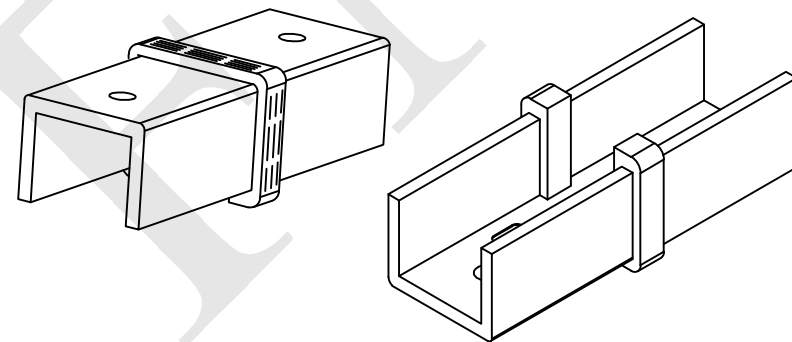
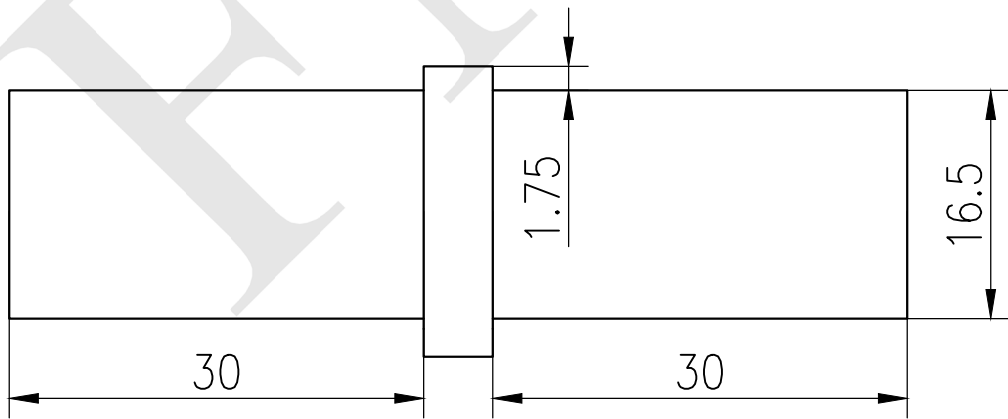
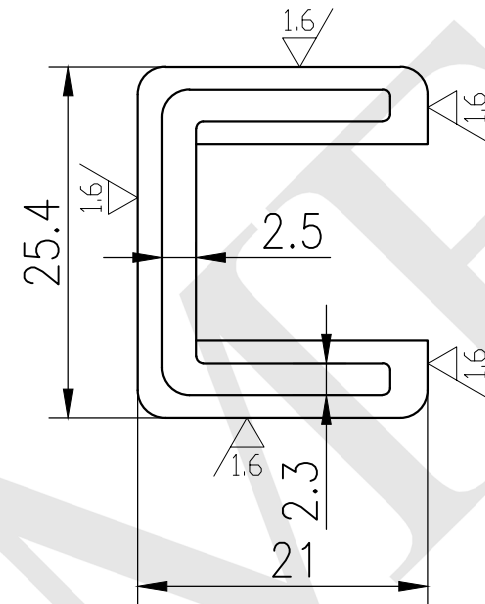
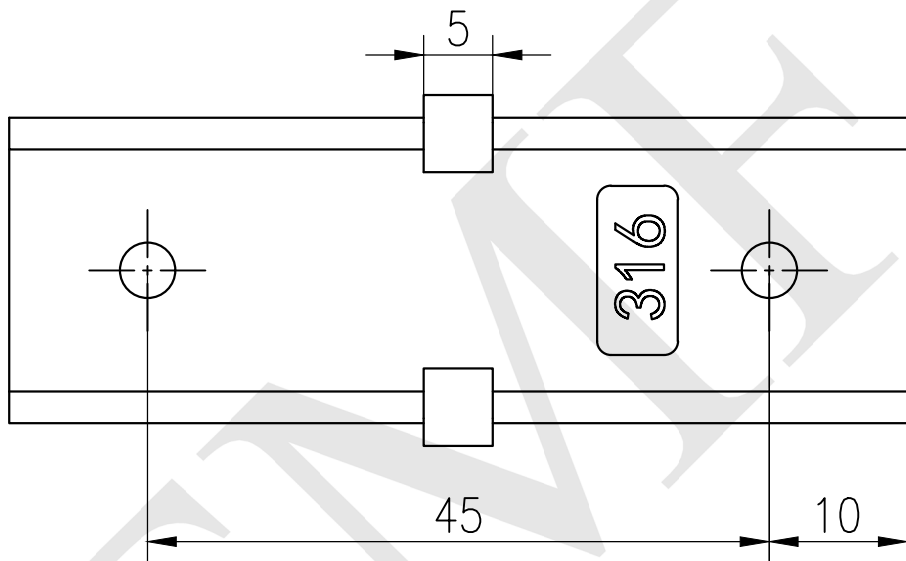

<b>NOTES:</b> - PROPRIETARY AND CONFIDENTIAL - THE INFORMATION CONTAINED IN THIS DRAWING IS THE SOLE PROPERTY OF FMF GLASS HARDWARE. ANY REPRODUCTION IN PART OR AS A WHOLE WITHOUT THE WRITTEN PERMISSION OF FMF GLASS HARDWARE IS PROHIBITED.	PRODUCT NAME: Straight Connector for Square Cap 25x21mm Handrail		PRODUCT MODEL NUMBER: SCC-2521		
	DWG NO. SCC-2521_1	UNIT: MM	DWG SIZE/SCALE A4/NTS	<b>FMF GLASS                  HARDWARE</b>	REV. 1
	DATE: 11.22	DRAWN BY: FMF	SHEET 1 OF 1		

12 11 10 9 8 7 6 5 4 3 2 1